



Vgraph

CANBUS USER INTERFACE WITH LCD GRAPHIC DISPLAY



ENGLISH

HARDWARE MANUAL ver. 1.01

CODE 114VGRAHWE01

Important

Important

Read these instructions carefully before installing and using the instrument and follow all additional information for installation and electrical connection; keep these instructions close to the interface for future consultations.

The interface must be disposed according to the local legislation about the collection for electrical and electronic equipment.



Index

- 1. INTRODUCTION 4
 - 1.1. Introduction..... 4
 - 1.2. Available models for the programmable controllers of the family c-pro 5
 - 1.3. Available models for the programmable controllers of the family c-pro 3 5
- 2. SIZE AND INSTALLATION 6
 - 2.1. Size 6
 - 2.2. Installation 6
 - 2.3. Additional information for installation 7
- 3. ELECTRICAL CONNECTION 8
 - 3.1. Electrical connection 8
 - 3.2. Additional information for electrical connection 9
- 4. CONFIGURATION 10
 - 4.1. Preliminary information 10
 - 4.2. Configuring the interface 10
 - 4.3. List of configuration parameters 11
 - 4.4. Configuring a device through the interface 14
- 5. SIGNALS 15
 - 5.1. Signals..... 15
- 6. ACCESSORIES 16
 - 6.1. Frontal plates CPVP* by Evco 16
 - 1.1.1. Available models 16
 - 1.1.2. Size 16
 - 6.2. Support for wall mounting CPVW00 16
 - 1.1.3. Available models 16
 - 1.1.4. Size 17
 - 6.3. Gasket 0027000007 17
 - 1.1.5. Available models 17
 - 1.1.6. Size 17
- 7. TECHNICAL DATA 18
 - 7.1. Technical data 18

1. INTRODUCTION

1.1. Introduction

Vgraph is a new and innovative user interface for the programmable controllers of the family *c-pro* that support the CAN bus and for the programmable controllers of the family *c-pro 3*.

The main features of the interface are the possibility to communicate to the user a great deal of information and the remarkable ease of control; these features are due to the use of a 128 x 64 pixel single colour LCD graphic display (black with rearlighting through white LED), to the 6 buttons (with preset functions) membrane keyboard and to the CAN bus (for the connection to the controllers).

This last also allows the use of the interface in multimaster networks.

Thanks to its constructive features, Vgraph offers several mounting typologies; this is possible:

- by panel, at the front of units, of machines for refrigeration or for air conditioning, of electrical panels and as well as in all those applications where a frontal protection degree IP65 is required
- built-in by wall, in traditional box (like "506" by BTicino)
- by wall, on the support CPVW00 by Evco (to order separately).

Also the necessity to customize the interface, in order to integrate it aesthetically in residential and commercial environments, is satisfied by Vgraph since at the front of the interface one can apply both the plates CPVP* by Evco (to order separately, made in plastic material and available in two different colorations, white and black) and the numerous plates series "Living" and "Light" by BTicino.

By request, Vgraph can be supplied with:

- real time clock
- alarm buzzer.



1.2. Available models for the programmable controllers of the family c-pro

The following table shows the available models and the respective main features.

Code	Main features
CPV3L2C4NX	Not isolated power supply 24 VAC or 20 ... 40 VDC, 128 x 64 pixel LCD graphic display
CPV3L2C4	Not isolated power supply 24 VAC or 20 ... 40 VDC, 128 x 64 pixel LCD graphic display, real time clock, alarm buzzer
CPV3L2C7NX	Isolated power supply 12-24 VAC or 15 ... 40 VDC, 128 x 64 pixel LCD graphic display
CPV3L2C7	Isolated power supply 12-24 VAC or 15 ... 40 VDC, 128 x 64 pixel LCD graphic display, real time clock, alarm buzzer

For further models, contact the Evco's sales network Evco at the address sales@evco.it.

1.3. Available models for the programmable controllers of the family c-pro 3

The following table shows the available models and the respective main features.

Code	Main features
EPV4GBR	Not isolated power supply 24 VAC or 20 ... 40 VDC, 128 x 64 pixel LCD graphic display, real time clock, alarm buzzer
EPV3GBR	Isolated power supply 12-24 VAC or 15 ... 40 VDC, 128 x 64 pixel LCD graphic display, real time clock, alarm buzzer

For further models, contact the Evco's sales network Evco at the address sales@evco.it.

2. SIZE AND INSTALLATION

2.1. Size

Size in mm (in).

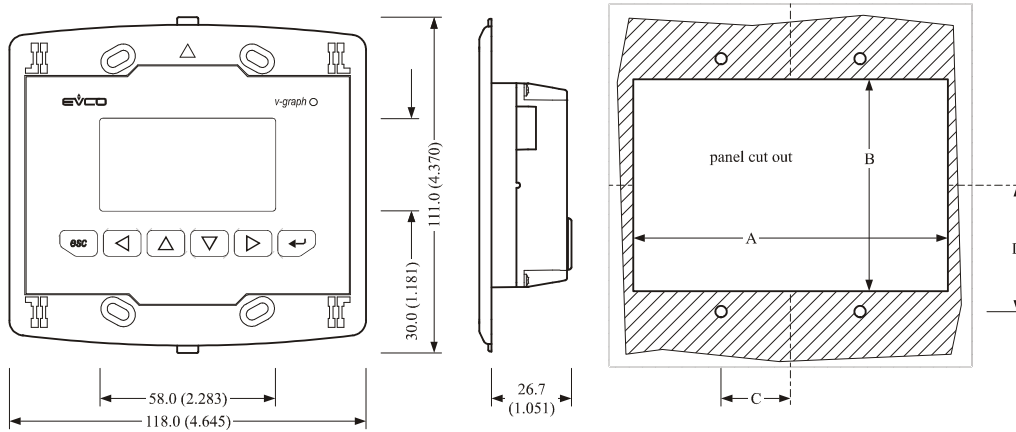

Size	Minimum	Typical	Maximum
A	104.0 (4.094)	104.0 (4.094)	104.8 (4.125)
B	70.0 (2.755)	70.0 (2.755)	70.8 (2.787)
C	22.0 (0.866)	23.0 (0.905)	24.0 (0.944)
D	40.8 (1.606)	41.8 (1.645)	42.8 (1.685)

2.2. Installation

The installation is possible:

- by panel
- built-in by wall, in traditional box (like "506" by BTicino)
- by wall, on the support CPVW00 by Evco (to order separately); look at chapter 6 (ACCESSORIES).

The following drawing shows the installation by panel, with 4 screws (supplied by the builder).

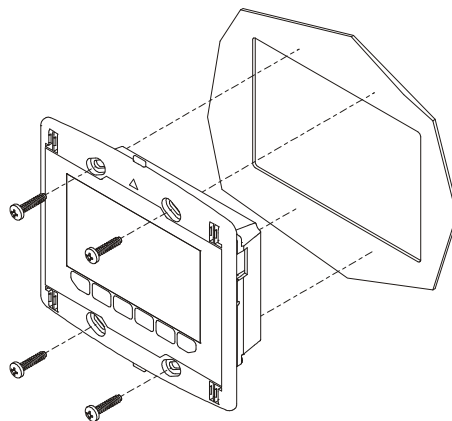

At the front of the interface one can apply the plates CPVP* by Evco (to order separately, made in plastic material and available in two different colorations, white and black); look at chapter 6 (ACCESSORIES).

2.3. Additional information for installation

- working conditions (working temperature, humidity, etc.) must be between the limits indicated in the technical data
- do not install the interface close to heating sources (heaters, hot air ducts, etc.), devices provided with big magnetos (big speakers, etc.), locations subject to direct sunlight, rain, humidity, dust, mechanical vibrations or bumps
- according to the safety legislation, the protection against electrical parts must be ensured by a correct installation of the interface; the parts that ensure the protection must be installed so that you can not remove them if not by using a tool.

3. ELECTRICAL CONNECTION

3.1. Electrical connection

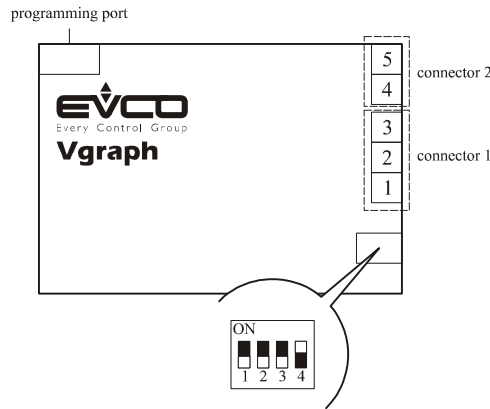

Position micro-switch 4 on position ON to plug in the termination of the CAN port; micro-switches 1, 2 and 3 are reserved.
 The following tables show the meaning of the connectors.

Connector 1: CAN port.

Terminal	Meaning
1	ground
2	signal +
3	signal -



The maximum length of the connecting cables of the CAN port of the interface depends on the baud rate of the CAN communication, as follows:

- 1,000 m (3,280 ft) with baud rate 20,000 baud
- 500 m (1,640 ft) with baud rate 50,000 baud
- 250 m (820 ft) with baud rate 125,000 baud
- 50 m (164 ft) with baud rate 500,000 baud.

Connect the CAN port of the interface using a twisted pair.

According to the default settings, the interface recognizes the baud rate automatically, on condition that it is one of the those mentioned above; hereinafter one suggests setting the same baud rate of the others devices in the network.

Connector 2: power supply (not isolated 24 VAC or 20 ... 40 VDC or isolated 12-24 VAC or 15 ... 40 VDC, according to the model).

Terminal	Meaning
4	power supply
5	power supply



The maximum length of the connecting cables of the power supply is 10 m (32.8 ft).

In the models with not isolated power supply, this must galvanically be isolated from the one of the other devices connected in the network.







3.2. Additional information for electrical connection

- do not operate on the terminal blocks with electrical or pneumatic screwdrivers
- if the interface has been moved from a cold location to a warm one, the humidity could condense on the inside; wait about an hour before supplying it
- test the working power supply voltage, working electrical frequency and working electrical power of the interface; they must correspond with the local power supply
- disconnect the local power supply before servicing the interface
- do not use the interface as safety device
- for repairs and information on the interface please contact Evco sales network.

4. CONFIGURATION

4.1. Preliminary information

The following table shows the main meaning of the buttons.

Button	Meaning
	button escape (hereinafter called "button ESC")
	button move to left (hereinafter called "button LEFT")
	button increase (hereinafter called "button UP")
	button decrease (hereinafter called "button DOWN")
	button move to right (hereinafter called "button RIGHT")
	button confirm (hereinafter called "button ENTER")

4.2. Configuring the interface

To gain access to the procedure operate as follows:

1. Switch off the power supply.
2. Keep pressed buttons ESC and RIGHT.
3. Switch on the power supply.
4. When the display shows the following menu (hereinafter called *Main menu*) release buttons ESC and RIGHT:

V-Graph
Parameters
Contrast
CAN Network
Modbus
Info
<i>Real date and time</i>



It is also possible to show the *Main menu* operating as follows:

5. Make sure the power supply is switched on.
6. Keep pressed 2 s buttons LEFT and ENTER: the display will show the following menu (hereinafter called *Network Status* menu):

Network Status			
Loc	99	OK	>> (back to the <i>Main menu</i>)
1	1	-	>>
2	0	-	>>
3	0	-	>>
4	0	-	>>
5	0	-	>>

7. Press and release button ENTER: the display will show the *Main menu*.

To gain access a submenu operate as follows:

8. From step 4, press and release button UP or button DOWN to select the submenu.
9. Press and release button ENTER.



The access to the *CAN Network* submenu is protected by password.

To gain access to the *CAN Network* submenu operate as follows:

10. From step 4, press and release button UP or button DOWN to select the submenu *CAN Network*.
11. Press and release button ENTER.
12. Press and release again button ENTER.
13. Press and release over and over again button DOWN to set “-19”.
14. Press and release button ENTER.

To modify a configuration parameter belonging to the *Parameters* submenu, to the *CAN Network* submenu or to the *Modbus* submenu operate as follows:

15. From step 9, press and release button UP or button DOWN to select the parameter.
16. Press and release button ENTER.
17. Press and release button UP or button DOWN to modify the value.
18. Press and release button ENTER to confirm the value.
19. Press and release button ESC to go back to the *Main menu*.

To modify the display's contrast operate as follows:

20. From step 4, press and release button UP or button DOWN to select the *Contrast* submenu.
21. Press and release button ENTER.
22. Press and release button UP or button DOWN to modify the value.
23. Press and release button ENTER to confirm the value.
24. Press and release button ESC to go back to the *Main menu*.

To modify the real date and time:

25. From step 4, press and release button UP or button DOWN to select the item *Real date and time*.
26. Press and release button ENTER.
27. Press and release button UP or button DOWN to modify the value.
28. Press and release button ENTER or button RIGHT to confirm the value and modify the following field.
29. Repeat steps 26 and 27.
30. Press and release button ESC to go back to the *Main menu*.

To quit the procedure:

31. Press and release over and over again button ESC: possible modifications will not be saved.



Switch off the power supply and then switch it on after the modification of the configuration.

4.3. List of configuration parameters

Submenu	Parameter	Min.	Max.	Unit	Default	Description
Parameters	DateCharSep	---	---	---	/	Date separator (ASCII character)
Parameters	Year format	---	---	---	YY	Year format YY = two numbers (for example 10) YYYY = four numbers (for example 2010)

Parameters	Date format	---	---	---	dmy	Date format ymd = year, month and day mdy = month, day and year dmy = day, month and year
Parameters	TimeCharSep	---	---	---	:	Time separator (ASCII character)
Parameters	TimeWithSec	0	1	---	1	Showing the seconds in the real time 1 = yes
Parameters	Time AM/PM	0	1	---	0	Time format 0 = 24 h (for example 15:20) 1 = 12 h (for example 3:20 PM)
Parameters	Back Mode	---	---	---	TIME	Backlight mode OFF = backlight is never lit ON = backlight is always lit TIME = backlight is lit the time one has set with parameter <i>BackTimeout</i> since the last operation with the buttons
Parameters	BackTimeout	0	240	s	60	Backlight duration (only if parameter <i>Back Mode</i> has value <i>TIME</i>)
Parameters	I/O Timeout	0	240	s	60	Local (or of the interface) CAN communication time-out (after this time without CAN communication, the display will show <i>Checking . . .</i> and the I/O of the interface will be disabled)
Parameters	PW Timeout	0	240	s	60	<i>CAN Network</i> submenu access password time-out (after this time without one has operated with the buttons, to gain access again to the submenu one has to set the password again)
Parameters	Contrast	0	63	---	25	Display's contrast
Parameters	Buzz On Key	0	1	---	1	Uttering a beep while pressing a button 1 = yes
Parameters	PrintLoad.	0	1	---	0	Showing the indication <i>Loading . . .</i> while loading a page 1 = yes
Parameters	Print Frame	0	1	---	0	Showing frames instead small size pages 1 = yes

CAN Network	MyNode	1	127	---	99	Local (or of the interface) CAN node's address
CAN Network	Master	---	---	---	YES	The interface always works as master
CAN Network	Baud	---	---	---	Auto	CAN communication baud rate 20K = 20,000 baud 50K = 50,000 baud 125K = 125,000 baud 500K = 500,000 baud Auto = the interface recognizes the baud rate automatically, on condition that it is one of the those mentioned above
CAN Network	Net Timeout	1	240	s	5	Remote (or of the devices in the network) CAN communication time-out (after this time without CAN communication with a device, this will be excluded by the network)
CAN Network	NW Node	[1] 1	[32] 127	---	---	Remote (or of the devices in the network) CAN nodes' address; example for [1] 2: [1] = node 2 = node's address
Modbus	Address	1	247	---	1	Modbus address (reserved)
Modbus	Parity	---	---	---	even	Modbus communication parity (reserved) none = no parity odd = odd even = even
Modbus	Baudrate	---	---	---	9600	Modbus communication baud rate (reserved) 1200 = 1,200 baud 2400 = 2,400 baud 4800 = 4,800 baud 9600 = 9,600 baud 19200 = 19,200 baud 28800 = 28,800 baud 38400 = 38,400 baud 57600 = 57,600 baud
Modbus	Bit Stop	---	---	---	1 bit	Modbus communication stop bit number (reserved)

4.4. Configuring a device through the interface

Operate as follows:

1. Switch off the power supply of the device and of the interface.
2. Connect the device to the interface through the CAN port; look at chapter 3 (ELECTRICAL CONNECTION).
3. Switch on the power supply of the device and of the interface.
4. Operate on the interface to set parameter *NW Node*; look at chapter 4 (CONFIGURATION).



Parameter *NW Node* belongs to the *CAN Network* submenu.

According to the default settings, the CAN node's address of a controller has value 1 (so operate on the interface to set parameter *NW Node* to [1] 1) and the CAN node's address of an expansion has value 2 (so operate on the interface to set parameter *NW Node* to [2] 2).

5. Keep pressed 2 s buttons LEFT and ENTER of the interface: the display will show the *Network Status* menu:

Network Status			
Loc	99	OK	>>
1	1	OK	>>
2	2	OK	>>
3	0	-	>>
4	0	-	>>
5	0	-	>>

6. Press and release button UP or button DOWN to select the device.
7. Press and release button ENTER: the display will show the device's *Main menu*.
8. Operate as indicated in paragraph 4.2 (Configuring the interface).



Switch off the power supply of the device and then switch it on after the modification of the configuration.

5. SIGNALS

5.1. Signals

The following table shows the meaning of the LEDS at the back of the interface.

LED	Meaning
POWER	if it is lit, the interface will be turned supplied
CAN RX	it provides information on the status of the receiving line of the CAN port
CAN TX	it provides information on the status of the transmitting line of the CAN port

6. ACCESSORIES

6.1. Frontal plates CPVP* by Evco

1.1.1. Available models

The following table shows the available models and the respective main features.

Code	Main features
CPVP00	plastic material, white
CPVP01	plastic material, black

1.1.2. Size

Size in mm (in).

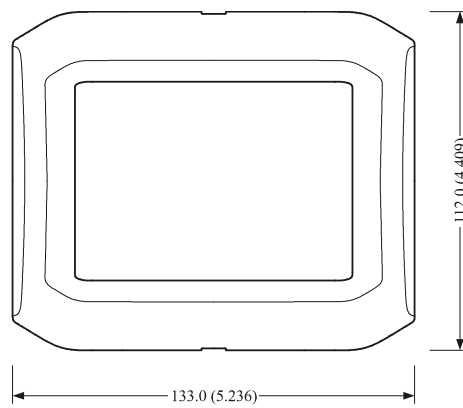

6.2. Support for wall mounting CPVW00

1.1.3. Available models

The following table shows the available models and the respective main features.

Code	Main features
CPVW00	plastic material, white

1.1.4. Size

Size in mm (in).

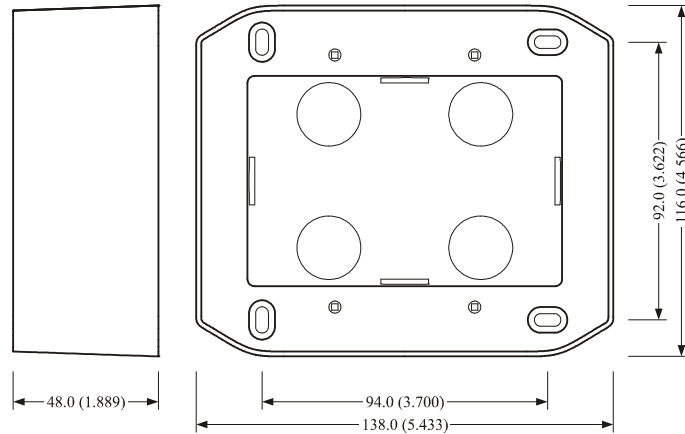

6.3. Gasket 0027000007

1.1.5. Available models

The following table shows the available models and the respective main features.

Code	Main features
0027000007	black, to get a frontal protection degree IP65 (only in case of panel mounting)

1.1.6. Size

Size in mm (in).

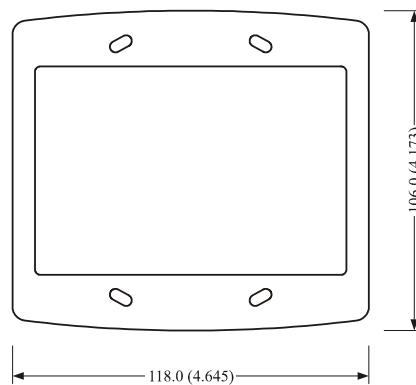

7. TECHNICAL DATA

7.1. Technical data

Purpose of control:	user interface for programmable controllers.
Construction of control:	electronic device to be incorporated.
Box:	self-extinguishing transparent.
Size:	118.0 x 111.0 x 26.7 mm (4.645 x 4.370 x 1.051 in). Size refers to the interface with connector 1 and connector 2 properly plugged.
Installation:	<p>the installation is possible:</p> <ul style="list-style-type: none"> - by panel - built-in by wall, in traditional box (like "506" by BTicino) - by wall, on the support CPVW00 by Evco (to order separately); look at chapter 6 (ACCESSORIES). <p>Fixing screws are always supplied by the builder.</p> <p>At the front of the interface one can apply the plates CPVP* by Evco (to order separately, made in plastic material and available in two different colorations, white and black); look at chapter 6 (ACCESSORIES).</p>
Frontal protection degree:	IP40 (IP65 for panel mounting with gasket 0027000007, to order separately); look at chapter 6 (ACCESSORIES).
Connections:	<p>extractable male + female terminal blocks (power supply and CAN port), 6 poles telephone connector (programming port).</p> <p>The maximum length of the connecting cables of the CAN port of the interface depends on the baud rate of the CAN communication, as follows:</p> <ul style="list-style-type: none"> - 1,000 m (3,280 ft) with baud rate 20,000 baud - 500 m (1,640 ft) with baud rate 50,000 baud - 250 m (820 ft) with baud rate 125,000 baud - 50 m (164 ft) with baud rate 500,000 baud. <p>According to the default settings, the interface recognizes the baud rate automatically, on condition that it is one of the those mentioned above.</p>
Working temperature:	from 0 to 50 °C (32 to 120 °F, 10 ... 90% of relative humidity without condensate).
Pollution situation:	2 or more.

<p>Power supply:</p>	<p>according to the model:</p> <ul style="list-style-type: none"> - 12-24 VAC (min. 11.4 VAC, max. 27.6 VAC), 50/60 Hz, 3 VA (approximate) isolated or 15 ... 40 VDC, 3 W (approximate) isolated - 24 VAC (min. 20.4 VAC, max. 27.6 VAC), 50/60 Hz, 3 VA (approximate) non isolated or 20 ... 40 VDC, 2 W (approximate) non isolated <p>supplied from a class 2 circuit.</p> <p>The maximum length of the connecting cables of the power supply is 10 m (32.8 ft).</p> <p>In the models with not isolated power supply, this must galvanically be isolated from the one of the other devices connected in the network.</p> <p>Protect the power supply with an UL listed or recognized fuse rated:</p> <ul style="list-style-type: none"> - 80 mA-T if the user interface is powered with 15... 40 VDC - 160 mA-T if the user interface is powered with 12... 19 VAC - 125 mA-T if the user interface is powered with 19... 24 VAC.
<p>Overvoltage category:</p>	<p>III.</p>
<p>Real time clock data maintenance in absence of power supply:</p>	<p>2 days will battery fully charged; the real time clock is available by request.</p>
<p>Battery charging time</p>	<p>2 min without interruptions (the battery is charged by the power supply of the interface).</p>
<p>Alarm buzzer:</p>	<p>by request.</p>
<p>Display:</p>	<p>128 x 64 pixel single colour LCD graphic display (black with rearlighting through white LED).</p>
<p>Communication ports:</p>	<p>2 ports:</p> <ul style="list-style-type: none"> - 1 non optoisolated CAN port - 1 programming port.

Vgraph

Hardware manual ver. 1.01

PT - January 2011

Code 114VGRAHWE01

This document belongs to Evco; unless you are authorized by Evco, you can not publish this document.

Evco does not take any responsibility about features, technical data and possible mistakes related in this document.

Evco does not take any responsibility about damages coming by the non-observance of additional information.

Evco reserves the right to make any change without prior notice and at any time without prejudice the basic safety and operating features.



Evco S.p.A.

Via Mezzaterra 6, 32036 Sedico Belluno ITALIA

Tel. 0437/852468

Fax 0437/83648

info@evco.it

www.evco.it